

Power

POWER CONNECTOR TERMINATION / HOOK UP PROCEDURE

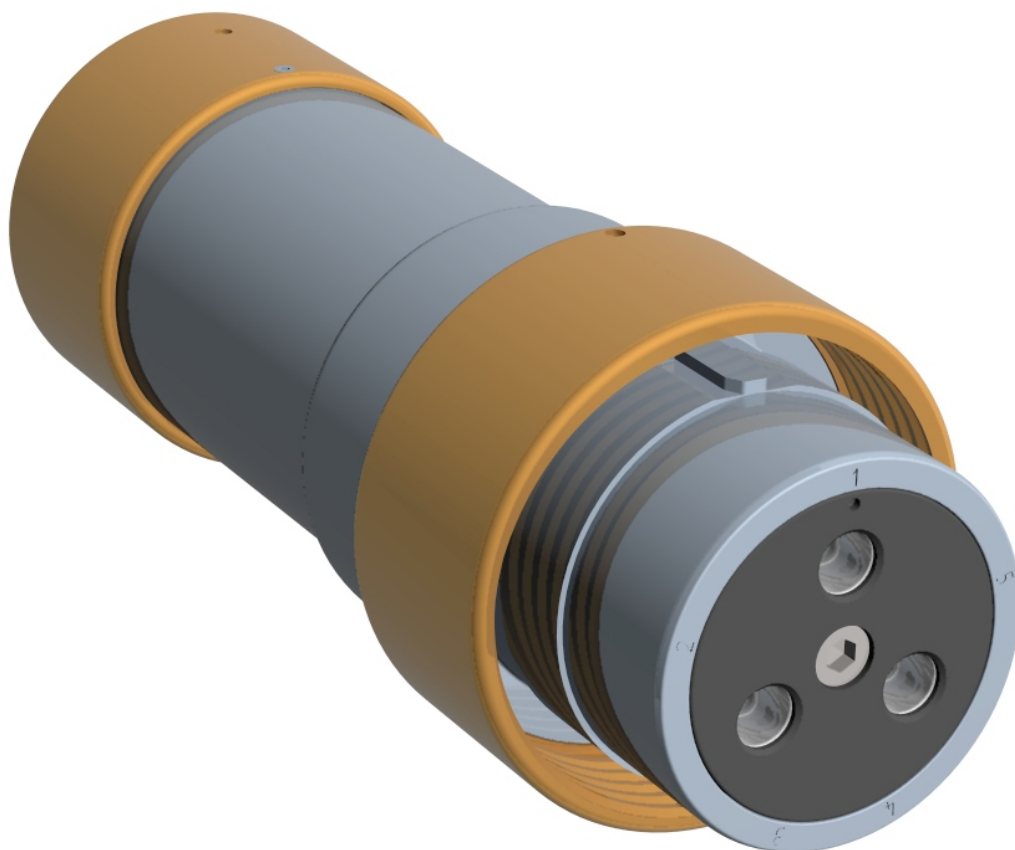

(AI365 Rev 5 – 01Mar16)

Hawke International
UK Office,
Oxford Street West,
Ashton-under-Lyne,
Lancashire.
OL7 0NA. UK

Sales: +44 (0) 161 830 6698
Technical: +44 (0) 161 830 6697
Fax: +44 (0) 161 830 6648
E-mail: sales@ehawke.com

Connection Solutions
www.ehawke.com

HAWKE
International



IMPORTANT NOTE

Hawke International does not recommend the use of their Power  Connectors in applications where rigid PVC / SWA / PVC power cabling (typically to BS 6346 standards) is used in portable / semi-portable applications.

In addition, Hawke recommends that barrier type glands are fitted to flexible power and loose filled control cabling entering the connectors to maintain the Exd protection concept and to reduce the potential for core movements within the cable being transferred to the connector's internal components.

CP / CR PROCEDURE

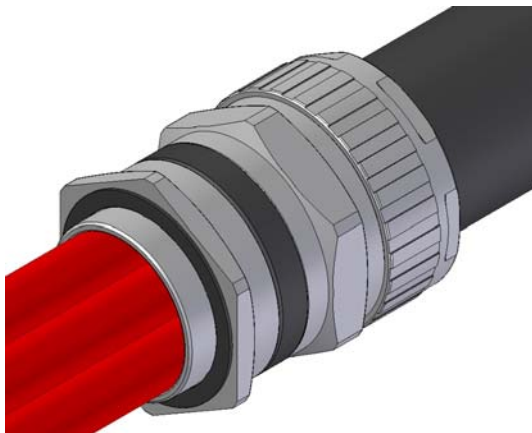
- 1) Terminate the cable into the Exd cable gland as per the manufacturer's instructions. Consider at this stage the relative position of the phases.



- 2) Cut the conductors to the lengths shown. (For earth conductors which are being terminated to the earth ring (see step 6) but not carried through the contact, cut back X = 100mm for all sizes, see 10 - 13)

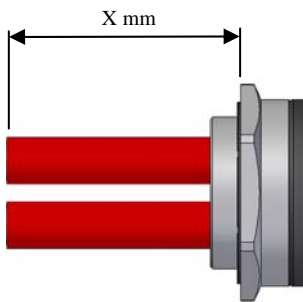

CONTACT SIZE	X mm (± 1.5mm)
50mm ²	147
70mm ²	147
95mm ²	147
120mm ²	146
150mm ²	146
185mm ² (ExP 40 & 50)	149
185mm ² (ExP 75)	159
240mm ² (ExP 40 & 50)	149
240mm ² (ExP 75)	159
300mm ²	167
400mm ²	172
500mm ²	188
630mm ²	188

- 3) Strip back the insulation as shown. (For all earth conductors terminated via the internal earth ring, cut back the insulation flush with the gland entry thread, see 10 - 13).



CONTACT SIZE	Y mm (± 1.5mm)
50mm ²	30
70mm ²	30
95mm ²	32
120mm ²	32
150mm ²	32
185mm ²	40
240mm ²	45
300mm ²	50
400mm ²	57
500mm ²	62
630mm ²	67

- 4) Unscrew the rear engaging nut from the CP / CR shell. Remove the rear shell, spacer tube and insert from the CP / CR shell.

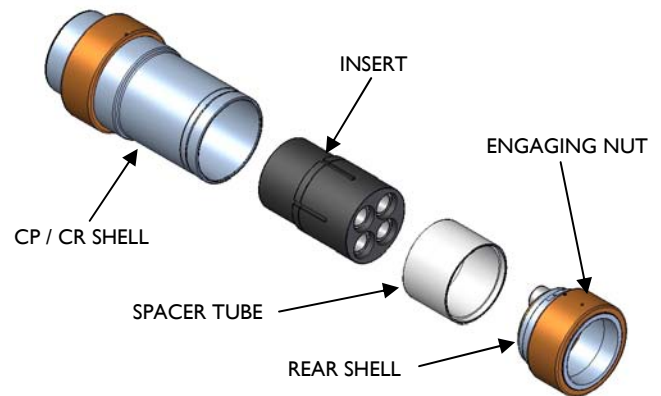

- 5) a) **CONTACT SIZES 50 - 240mm².** Remove the screws from the front of the contacts only and push the crimp lugs out of the insert.



- b) **CONTACT SIZES 300 – 630mm².** Remove the screw from the plastic housing and remove the contact from inside.

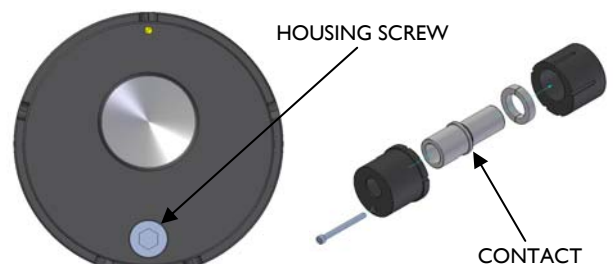

- 6) Remove the internal earth ring from the rear shell sub assembly by backing off the 2 grub screws on the flats. If internal earthing is not required, the internal earth ring assembly along with the fixing grub screws should be discarded.

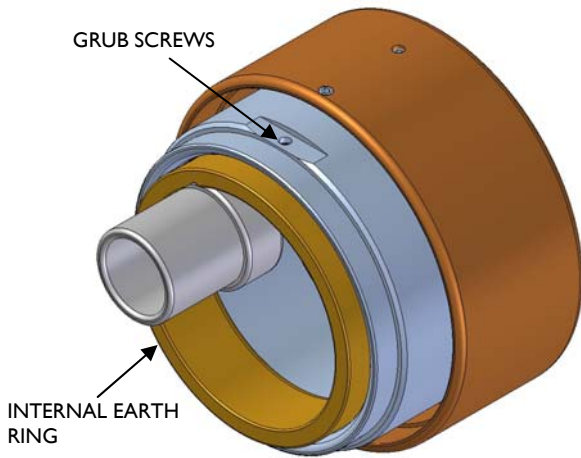

- 7) Crimp the lugs or contacts onto the conductors (excluding internal earth wire if being used) using suitable crimp tool. (Hawke recommend Elpress crimp tools). Contact sizes of 185mm² and larger should be adjacently double crimped as shown.

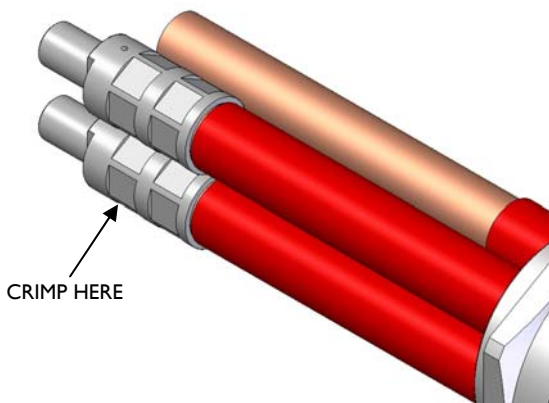

- 8) Feed the conductors through the rear shell assembly and screw this onto the cable gland entry thread ensuring the sealing washer is present.

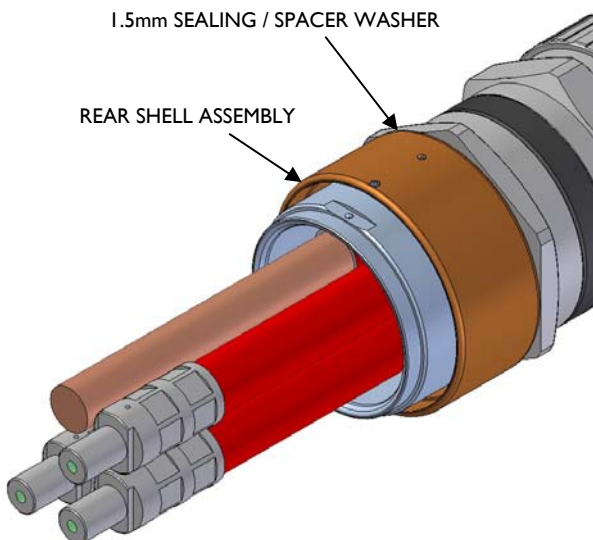

- 9) Measure the distance from the front of the rear shell to the end of the crimp lug (50 – 240mm²) or contact (300 – 630mm²). It should be as shown. If not, remove the rear shell and add or remove the spacer washers supplied to get the required length. At least 1 washer must be present to maintain IP rating.

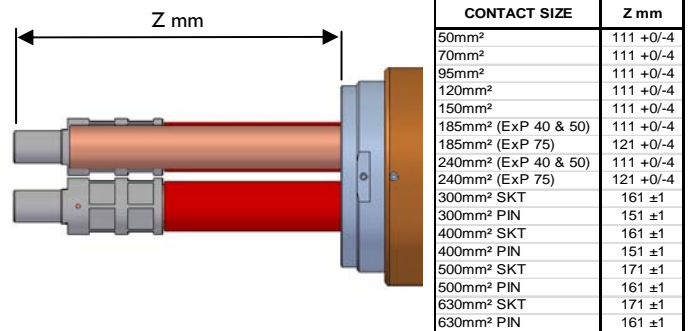

Internal earth procedure (skip to step 13 if not used or you have single phase connector).

- 10) Slide the internal earth ring down over the conductors with the lug going over the bare earth wire.

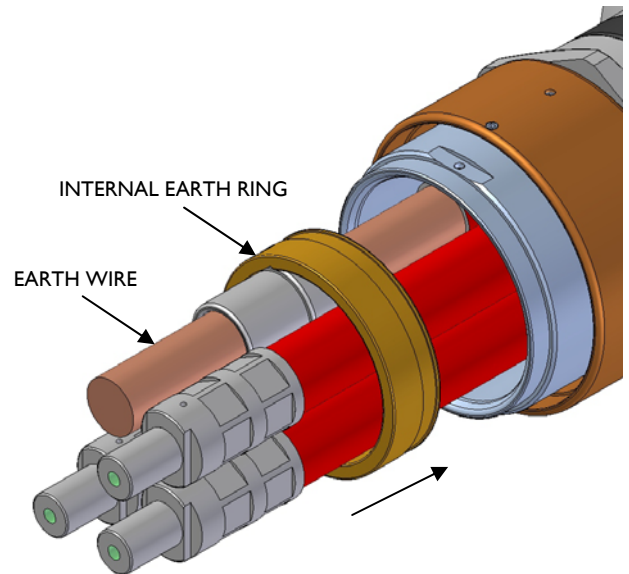

- 11) Position the internal earth ring inside the rear shell and tighten the grub screws into the groove on the earth ring. Excessive force could distort rear shell.

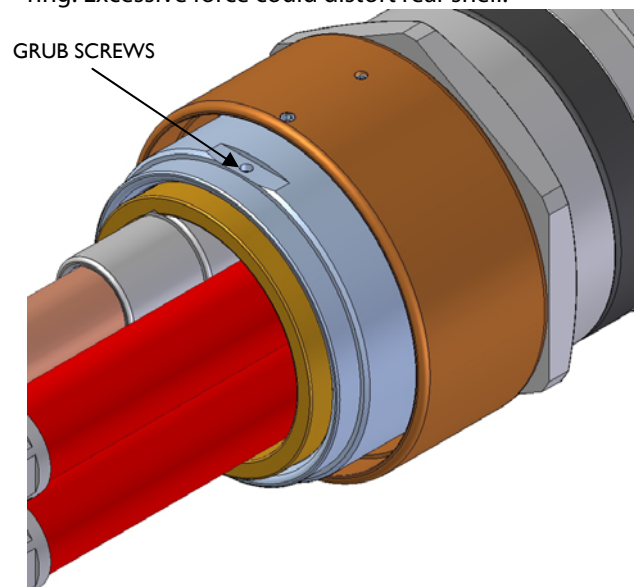

- 12) Tighten the 2 grub screws on the internal earth lug into the earth conductor as tight as possible so that the earth wire is sufficiently clamped. If earth is to be carried through to a contact, crimp contact prior to tightening grub screws.

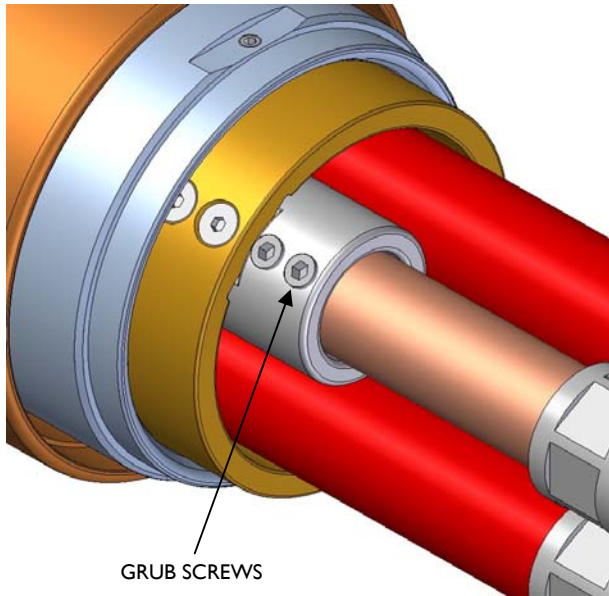

- 13) Slide the spacer tube over the conductors and onto the rear shell.

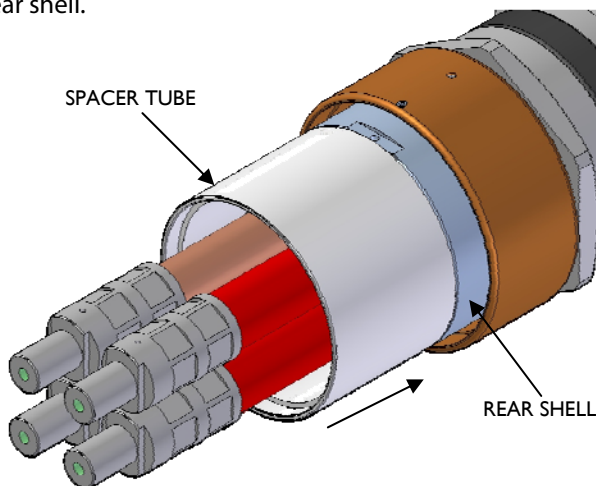

- 14) a) **CONTACT SIZES 50 - 240mm².**
Push the insert assembly fully onto the crimp lugs. The insert should push inside the spacer tube. Refit the 4 screws into the ends of the contacts. Ensure these are fully tightened.

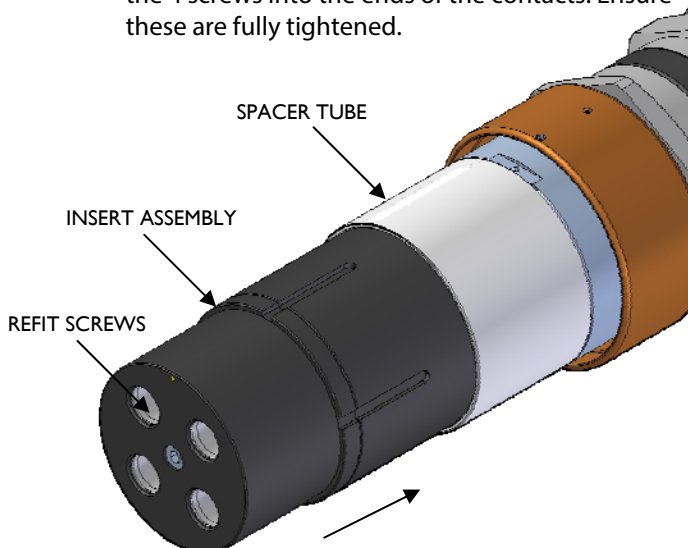

- b) **CONTACT SIZES 300 – 630mm².**
Push the rear retainer over the contact. Place the split tube around the contact. Slide the front contact retainer over the contact and split tube. Slide the rear contact retainer over the rear of the contact and tighten the screw fully.

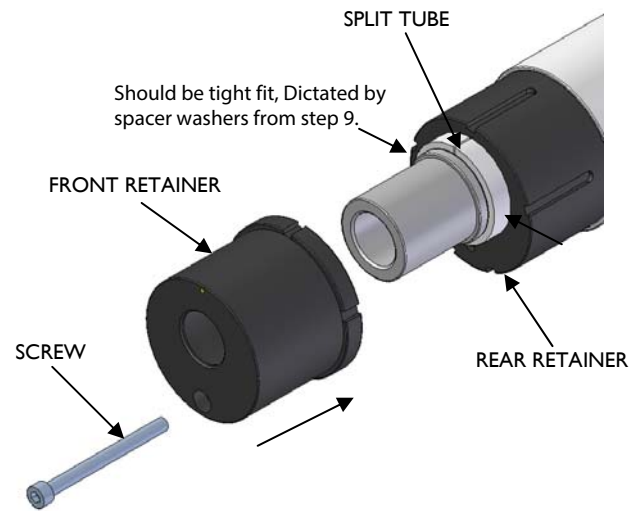

- 15) Slide the CP / CR shell over the insert and line the yellow dot on the insert up with the required keying position 1 to 5 marked on the CP / CR shell.

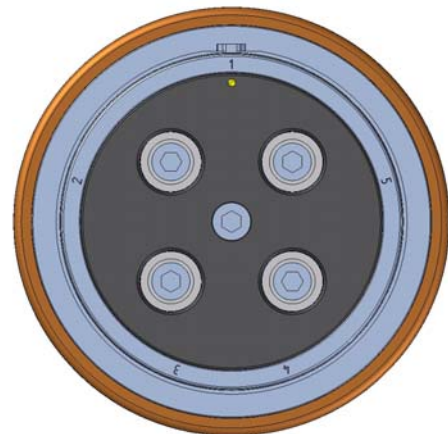

- 16) Screw the rear engaging nut fully onto the CP / CR shell. Measure the distance between the front of the rear engaging nut to the back of the engaging nut which should be no greater than the distance shown.

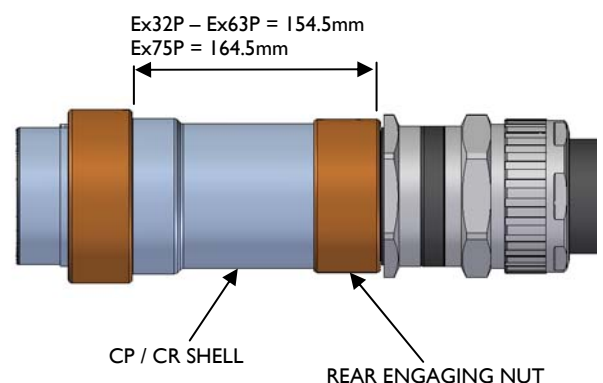

- 17) Tighten down the 2 grub screws on the rear engaging nut.

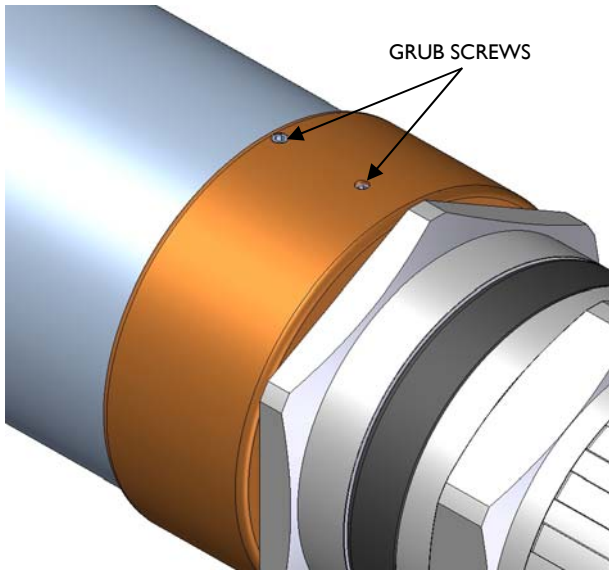

- 18) Terminate the equipotential external earth to the ring terminal crimp provided if applicable. Remove the button head screw, spring washer and crimp from the rear engaging nut. Crimp the external earth wire into the crimp and reassemble.

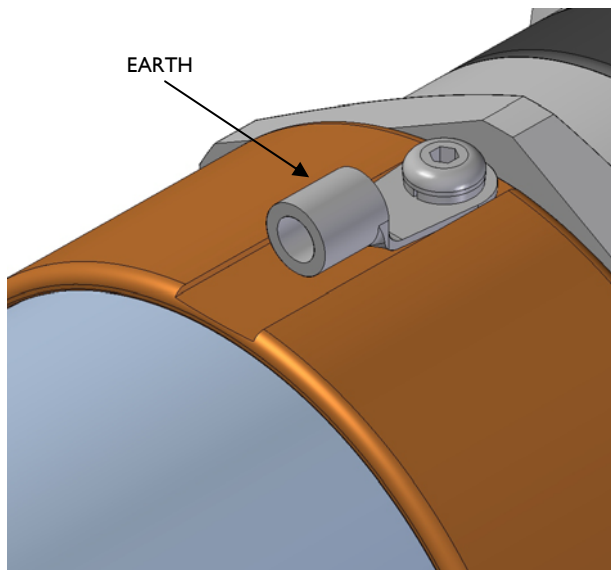

- 19) Refit the protective or flameproof cap if applicable.

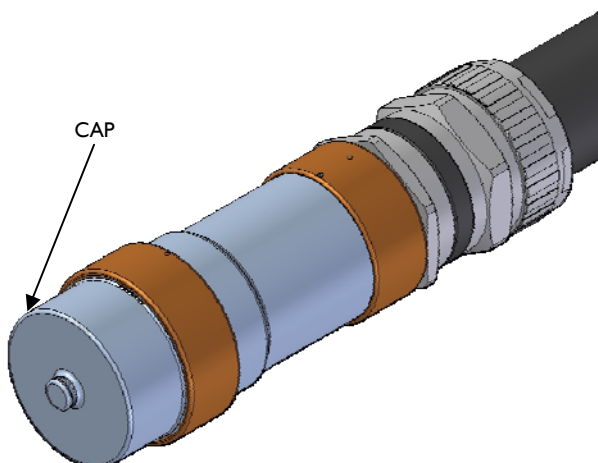

- 20) The connector is now ready for installation. Please refer to the hook up procedure.

HOOK UP PROCEDURE

Before commencing hook up, a visual inspection should be carried out on the cable / gland / connector assembly. The assembly should be checked to ensure that all of the assembly components are tight. If the assembly components have loosened during transportation / cable installation, they should be retightened in accordance with the relevant assembly instruction sheets without twisting the cable in the cable gland / connector assembly. No hazardous gases should be present.

- 1) Turn off the power to the connectors.
- 2) Ensure the connectors are both set to the same keying position number, are of the same insert type and phase orientation.

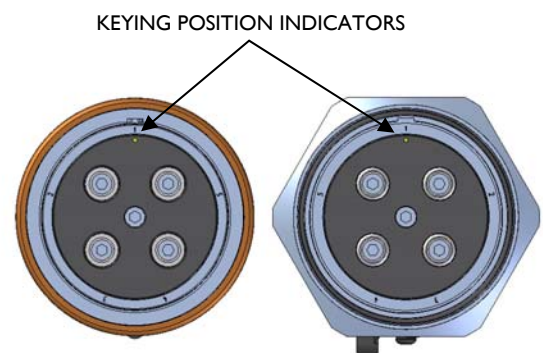

- 3) Engage the CP connector with the BR / CR connector and align the key on the CP connector to the keyway on the BR / CR connector.

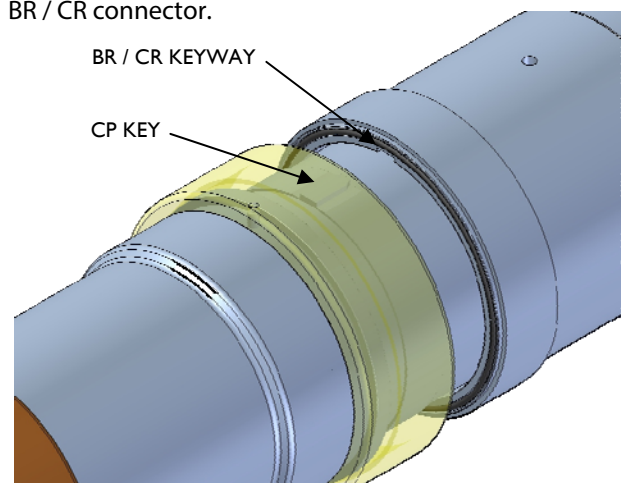

- 4) Engage the two connectors by screwing the engaging nut clockwise onto the BR/CR shell. If the engaging nut will not screw on more than half a turn, then the connectors are set to different keying positions.

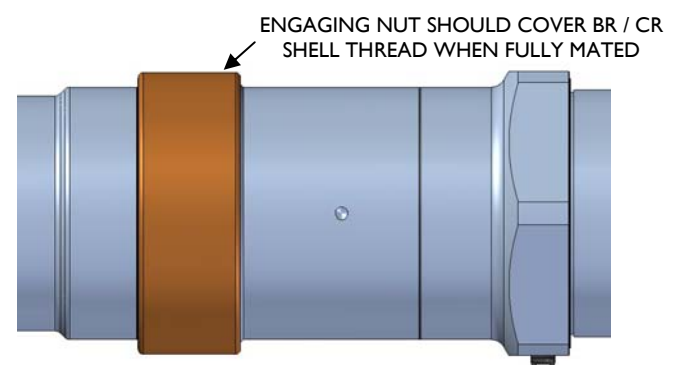

- 5) Fully tighten the engaging nut with strap wrench if necessary and then tighten the grub screw on the engaging nut.

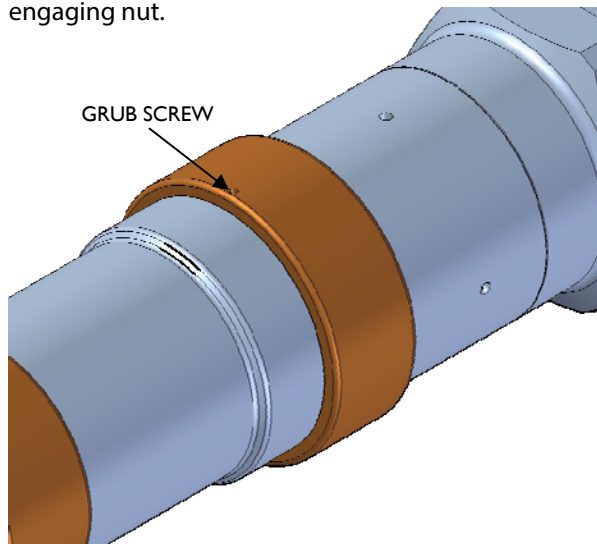

- 6) To disconnect, **turn off the power** (no hazardous gases should be present), slacken the tightened grub screw, turn the engaging nut anti-clockwise and remove the connector. If power is to be put through the connectors whilst demated, then a flameproof cap (available separately) **must be fitted**.

SCHEDULE OF LIMITATIONS

- These connectors must be electrically isolated before any attempt is made to remove the covers or join or separate the two halves.
- When separated the metal flameproof caps (not the acetal environmental caps) shall be fitted and locked before any associated supply cables are re-energised.
- The cable entry devices selected for use with the in-line connectors shall provide a mechanical cable retention facility appropriate to the cable type and conditions of service.
- When used in dust environments the cable entry threads shall be sealed in accordance with the installation code of practice to ensure that an ingress protection level of IP6X is maintained.
- Flameproof joints are not intended to be repaired.

TECHNICAL SPECIFICATION

All Hawke Power  connectors have a maximum working voltage of 750VAC.

Other voltage ratings available on special request.

CONNECTOR SIZE	UPPER AMBIENT = 40°C		UPPER AMBIENT = 50°C		UPPER AMBIENT = 60°C	
	TEMP CLASS		TEMP CLASS		TEMP CLASS	
	T6	T5	T6	T5	T6	T5
32	20.5W	27.5W	15.75W	26W	7.5W	15.75W
40	22.5W	30.5W	17.5W	28W	8.7W	17.5W
50	25.8W	35.3W	20W	32.25W	10W	20W
63	30.2W	41.5W	23.5W	37.7W	11.7W	23.5W
75	36.3W	49.5W	28.25W	45.25W	14W	28.25W

- For determination of maximum current ratings please refer to catalogue.
- Do not exceed maximum dissipated wattage.
- No maintenance or servicing is required on this product.

Certification:  II2GD Exdb IIC T* Gb, Extb IIIC T85°C Db
Exd IIB+H₂ T* Gb, Extb IIIC T***C Db

Tamb: -40°C to +60°C

Baseefa06ATEX0062X IECEx BAS06.0019X CSA 2633583

Inmetro IEx 14.0218X EAC RU C-GB.ГБ05.В.00750

IP Rating: IP66 / 67 (IP68 on request)

Deluge Rating: DTS01

EC Declaration of Conformity in accordance with European Directive 94/9/EC (until 19th April 2016) and

EU Declaration of Conformity in accordance with European Directive 2014/34/EU (from 20th April 2016)

Manufacturer: Hawke International

Address: Oxford Street West, Ashton-under-Lyne, OL7 0NA, United Kingdom

Equipment Type: Range of Connectors: PowerEx Ex 32 to Ex 75

Provisions of the Directive fulfilled by the Equipment:

Group II Category 2GD Exdb IIC Gb, Extb IIIC Db – IP66

Notified Body for EC-Type Examination: SGS-Baseefa 1180 Buxton UK

EC-type Examination Certificate: Baseefa06TEX0061X

Notified Body for production: SGS-Baseefa 1180 Buxton UK

Harmonised Standards used:

EN 60079-0:2012, EN60079-1:2014, EN60079-31:2014

On behalf of the above named company, I declare that, on the date the equipment accompanied by this declaration is placed on the market, the equipment conforms with all technical and regulatory requirements of the above listed directives

A. Tindall
Technical Manager